

# SOLID STATE BATTERY 'FUEL' GAUGE & HOUR METER

MODEL 803



CURTIS



## DESCRIPTION

Curtis Model 803 combines in one instrument a completely solid state battery discharge indicator, an LCD hour meter and lift lockout, housed in a 52mm case. Void of moving parts, this combination instrument is exceptionally reliable even in severe operating environments.

## APPLICATION

Model 803 is a combination gauge ideally suited for electrically powered vehicles.

## FEATURES

### 'Fuel' Gauge Features

- Multicolor 10-bar LED displays state of charge (5 green, 3 yellow, 2 red LEDs).
- Flashing red LED signals "energy reserve" alarm at 70% discharged.
- Double flashing red LEDs signal "empty" alarm at 80% discharged.
- Normally closed relay opens at 80% discharge for lift lockout. This unique holding relay will only lock out at the end of a lift cycle.
- Recognizes improperly charged battery.
- Keyswitch activated LED display (Fuel gauge electronics are energized as long as they remain connected to the battery).
- Wide range adjustable discharge profile.
- Dual reset methods in each gauge: Open Circuit Reset for vehicles that exchange batteries and Charge Tracking Reset for vehicles whose batteries remain connected to the gauge during recharge.

### Hour Meter Features

- Monitors use-time throughout the equipment's lifespan.
- Records and displays up to 99,999.9 hours on its LCD, rolls over and continues to count and display.
- Hour meter LCD remains on as long as battery is connected.
- Stores latest total in EEPROM nonvolatile memory, without need of power.
- Operates and displays in temperatures from  $-40^{\circ}\text{C}$  to  $+65^{\circ}\text{C}$  under harsh conditions of vibration, shock, moisture and dust.

### System Voltages

Available in single voltages from 12 VDC to 80 VDC, or in dual voltage of 24/36, 36/48, 24/48 or 72/80 VDC. Operating range is  $\pm 25\%$  of nominal voltage.

# MODEL 803

## SPECIFICATIONS

- Hour meter accuracy: +0.1%
- Operating Temperature: -40°C to +65°C
- Shock & Vibration: Meets SAE J 1378
- Humidity: 95% RH (non-condensing) at +38°C
- LCD Character Height: 5 mm
- Mating Connector: Molex 8 pin, 39-01-2085
- Discharge Range: Empty from 1.57 volts/cell to 1.93 volts/cell
- Reset Levels: Open circuit reset (OCR) at 2.09 volts/cell  
Charge Tracking Reset (CTR) tracks battery recharge

## MODEL NUMBER DESCRIPTION

803 RB Case Style	2448 Voltage	B Reset Type /Level	C Discharge Profile	J Output	3zzO OEM Code
RB=Round (52mm) w/black bezel	12 2436 2448 3648 7280	B=CTR/OCR (3zzO) =HVR/OCR (1zzO/2zzO) where OCR=2.09vpc HVR=2.35vpc	C=Adjustable 1.57vpc to 1.93vpc at empty	J=N.C. holding relay Contact rating=3 Amps when continuously closed, 1 Amp when opening. K=N.C. relay Y=N.O. relay contact rating=1 Amp	(2zzO and 1zzO are earlier versions) O=Curtis logo

## DIMENSIONS mm

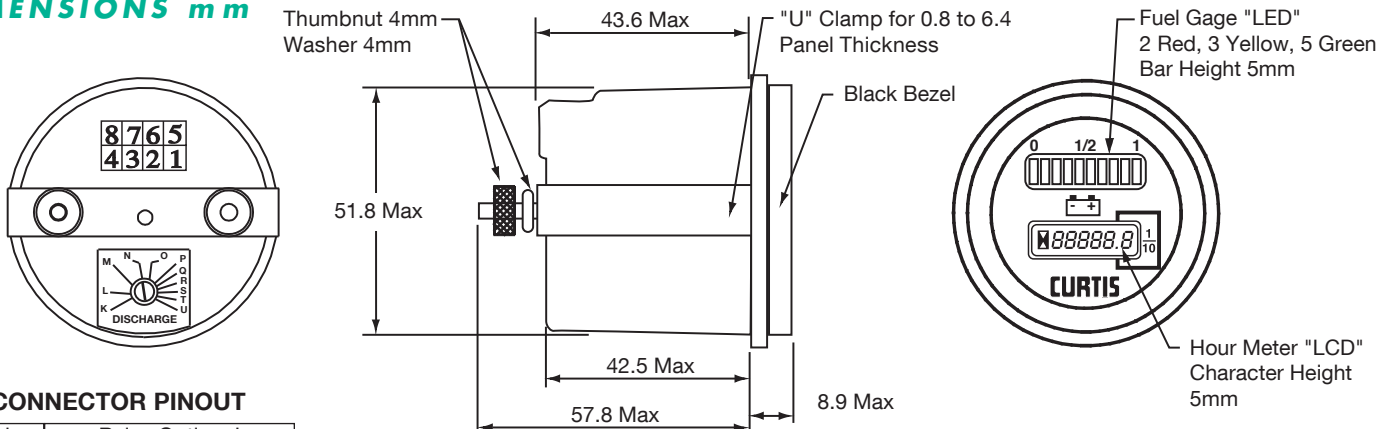

### CONNECTOR PINOUT

Pin No.	Relay Option J
1	HRM (-)
2*	Keyswitch
3	Relay ARM (+)
4	Relay N.C. (-)
5	Common (B-)
6	HRM (+)
7	B+ Low
8	B+ High

Note: In addition to a "U" clamp and thumbnuts/washers shown in the drawing, individually packed units are provided with a mating connector and female pins. Bulk packed units are provided with a "U" clamp and hex nuts/washers only.

\*Keyswitch turns on "fuel gauge" display and enables the hour meter. To accumulate time in the hour meter one or both of the HRM+ and HRM- inputs must be connected.

**WARRANTY** Two year limited warranty from time of delivery.

The Curtis Difference  
You feel it when you drive it

