

Dimension

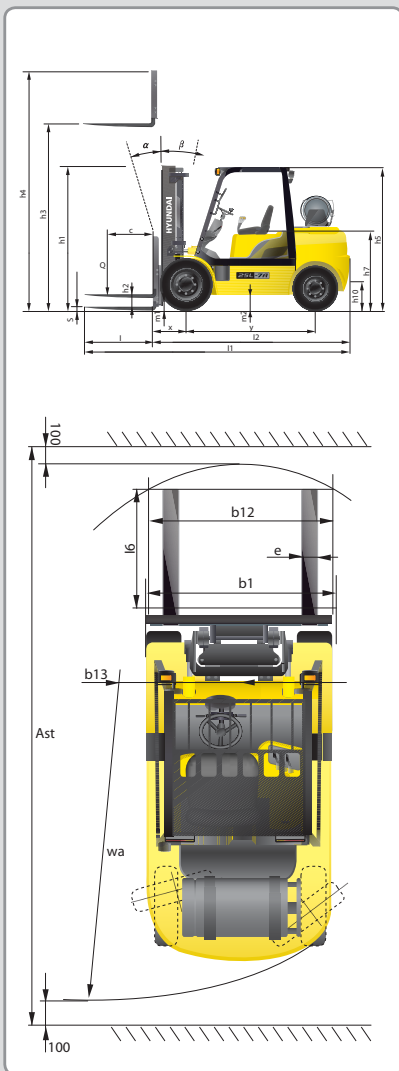

Specification

Identification			
1.1	Manufacturer	Hyundai	Hyundai
1.2	Manufacturer's type designation	Z5L-7A	30L-7A
1.3	Drive: electric (battery or mains), diesel, petrol, fuel gas, manual	LP / GAS	LP / GAS
1.4	Type of operation: hand, pedestrian, standing, seated, order-picker	seated	seated
1.5	Load capacity / rated load	Q (kg) 2,500	3,000
1.6	Load center distance	c (mm) 500	500
1.8	Load distance, center of drive axle to fork	x (mm) 468	468
1.9	Wheelbase	y (mm) 1,650	1,700
Weights			
2.1	Service weight	kg 3,740	4,220
2.2	Axle loading, loaded front/rear	kg 5,478 / 762	6,316 / 905
2.3	Axle loading, unloaded front/rear	kg 1,511 / 2,229	1,607 / 2,613
Wheels, Chassis			
3.1	Tires: solid rubber, superplastic, pneumatic, polyurethane	Pneumatic	Pneumatic
3.2	Tires size, front (width x D)	7.00 - 12 - 12PR	28 x 9 - 15 - 14PR
3.3	Tires size, rear (width x D)	6.00 - 9 - 10PR	6.50 - 10 - 12PR
3.5	Wheels, number front x rear (x = driven wheels)	2 x 2	2 x 2
3.6	Track width, front	b10 (mm) 965	1,005
3.7	Track width, rear	b11 (mm) 980	980
Basic Dimensions			
4.1	Mast / fork carriage tilt forward / backward (α / β) degrees	6 / 10	6 / 10
4.2	Lowered mast height	h1 (mm) 2,175	2,190
4.3	Free lift	h2 (mm) 155	155
4.4	Lift height	h3 (mm) 3,300	3,300
4.5	Extended mast height	h4 (mm) 4,485	4,485
4.7	Overhead load guard (cab) height	h5 (mm) 2,160	2,180
4.8	Seat height / standing height	h7 (mm) 1,110	1,130
4.12	Coupling height	h10 (mm) 282	300
4.19	Overall length	l1 (mm) 3,639	3,742
4.20	Length to face of forks	l2 (mm) 2,589	2,692
4.21	Overall width	b1 (mm) 1,160	1,230
4.22	Fork dimensions	s / e / l (mm) 1,050 x 100 x 45	1,050 x 122 x 45
4.23	Fork carriage ISO 2328, class / type A,B	II / A	III / A
4.24	Fork-carriage width	b12 (mm) 1,102	1,102
4.31	Ground clearance, loaded, under mast	m1 (mm) 130	145
4.32	Ground clearance, centre of wheelbase	m2 (mm) 171	189
4.33	Aisle width for pallets 1000 x 1200 crossways	Ast (mm) 3,965	4,066
4.34	Aisle width for pallets 800 x 1200 lengthways	Ast (mm) 4,165	4,266
4.35	Turning radius	Wa (mm) 2,297	2,398
4.36	Smallest pivot point distance	b13 (mm) 714	731
Performance Data			
5.1	Travel speed, Unloaded	km/h 18.1	19
5.2	Lift speed, Loaded/Unloaded	mm/s 600 / 610	580 / 610
5.3	Lowering speed, Loaded/Unloaded	mm/s 500 / 450	500 / 450
5.5	Drawbar pull, Loaded	kg 2,256	2,141
5.7	Gradient performance, Loaded/Unloaded	% 34.2 / 21.6	27.5 / 22.5
5.10	Service brake	Mechanic / Hydraulic	Mechanic / Hydraulic
Engine			
6.1	Engine manufacturer / type	HMCL4K8	HMCL4K8
6.2	Engine power acc. to ISO 1585	PS 60	60
6.3	Rated speed	1/min 2,300	2,300
6.4	No. of cylinder / cubic capacity	/cm ³ 4 / 2,359	4 / 2,359
Other Details			
8.2	Type of drive control	Power Shift	Power Shift
8.3	Operating pressure	bar 225 / 168	225 / 168
8.4	Oil volume	l/min 30	30
8.5	Noise	db(A) 80	80



■ Some of the photos may include optional equipment.

HYUNDAI LPG/GASOLINE FORKLIFT TRUCKS Applied Tier 4 Engine

25L/30L-7A

25G/30G-7A

HYUNDAI
HEAVY INDUSTRIES CO., LTD.

АО «РусТранс»

142116, Россия, МО, г. Подольск,
Домодедовское шоссе, д. 45А
Тел./факс: +7(495) 221-5070
<http://www.pogruzchik-hyundai.ru>
sales@pogruzchik-hyundai.ru

АО «РусТранс» - официальный представитель корпорации Hyundai Heavy Industries Co., Ltd. в России.

HYUNDAI
HEAVY INDUSTRIES CO., LTD.

We build a better future

NEW criteria of Forklift Trucks

Hyundai introduces a new line of 7A series
LPG / Gasoline forklift trucks.
Excellent power and performance make your
business more profitable.



OPSS (Operator Presence Sensing System)

Control of mast tilting, lifting and lowering is not possible through operation of the appropriate control when the operator is not in the seated position. (Option)

■ Some of the photos may include optional equipment.

The new master on the job-site!

Smooth running, efficient and ergonomically designed, 25L/30L-7A, 25G/30G-7A series are made to meet your needs.

60PS/2,300rpm



Powerful Engine HMC L4KB(2.4L) Engine

Market approved quality of HMC L4KB engine ensures incomparable performance, durability and additional value to the machine. Powerful and efficient engine provides excellent fuel consumption and excellent torque improved operator's comfort.
(EPA/CARB Tier-IV Certified)

Fast and Stable Performance

Being able to quickly raise and lower the mast, as well as tilt it forward and backward, provides the best operational conditions during unloading.

When the truck is fully loaded, mast lowering speed is carefully controlled to ensure safety by the down control valve.

Mast(Lift and Tilt) Look System. (Option)



■ Some of the photos may include optional equipment.

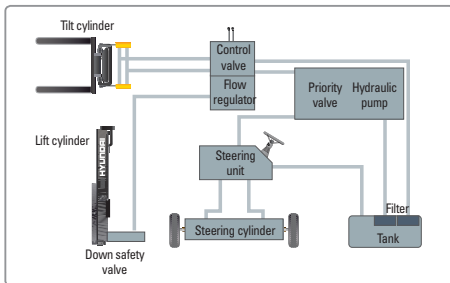

State-of-the-art Hydraulic System

The latest large-capacity hydraulic system reacts quickly during operation, and a low-noise control valve increases both efficiency and durability.



Fully Hydrostatic Power Steering

A hydraulic steering system always guarantees smooth and flexible steering, preventing overrun and kick-back.



Increased Mast Tilting Angle

Utilizing the mast tilting angle of 6 degrees forward and 10 degrees backward, the operator can safely and rapidly perform loading and unloading jobs.

Faster Travel Speed & Better Gradability

The powerful high-output engine provides greater acceleration, better gradability and faster travel speed on any tough terrains or slopes.

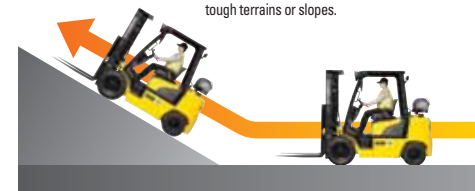

Gradability(Loaded)

25L-7A/25G-7A : 18.9°
30L-7A/30G-7A : 15.4°

Travel Speed(Unloaded)

25L-7A/25G-7A : 18.1 km/h
30L-7A/30G-7A : 19.0 km/h

Ergonomic operator friendly compartment design!

A design based on human engineering relieves fatigue and increases operator's efficiency.

Operator Friendly Gauges and Water-resistant Monitor Panel

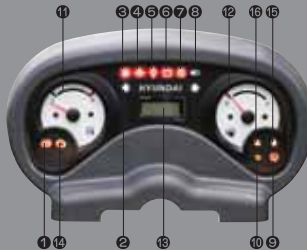

- ① Parking brake lamp
- ② Directional indicators
- ③ Fuel warning lamp
- ④ Engine oil warning lamp
- ⑤ Transmission oil temperature warning lamp
- ⑥ Battery charging warning lamp
- ⑦ Air cleaner filter warning light
- ⑧ Working light indicator
- ⑨ Water separator lamp
- ⑩ Pre-heater indicator
- ⑪ Water temperature gauge
- ⑫ Fuel gauge
- ⑬ Hour meter
- ⑭ Engine check lamp
- ⑮ Seat belt warning
- ⑯ OPS warning



Full Suspension Seat

An attractive and adjustable seat, based on a human engineering design, provides great comfort, safety and durability.



New High Visibility for Safe Operation

The operator is able to work with increased safety and accuracy due to a wider view mast.



Travel Speed Control System (Option)



- ← In-Door : Max. Travel Speed 5 ~ 8 km/h
- ← Out Door : Max Travel Speed 10 ~ 12 km/h

■ Some of the photos may include optional equipment.



Ergonomically Positioned Pedals

Based on human engineering, the accelerator, brake and inching pedals are optimally positioned for convenience while operating the equipment.



Cup Holder & Console Box

Additional storage spaces are located inside the operating space for operator's convenience.



Quick Response of Operating Control Levers

Only minimal operator's effort is required for precise, safe and productive control.



Adjustable Steering Wheel

Steering wheel with horn button can be adjusted by a lever on the right-hand side for the most comfortable operator position.



Easy and Safe Shift Lever

A single lever on the left side of the steering column gives the operator fast, easy control of direction. The lever must be in the neutral position before the engine can be started.



Secondary Horn

Secondary Horn gives access to lights and horn

Danger-free through high durability!

Safety and durability are priorities in design of the equipment.



Strong Overhead Guard

The safety overhead guard meets ISO 6055 regulation and protects the operator during hazardous jobs.



Parking Brake

Ratchet type parking brake requires less effort from the operator to set.

Highly Durable Split Type Drive Axle

The bevel gear set and hub reduction axle smoothly delivers desired torque to the drive wheels.

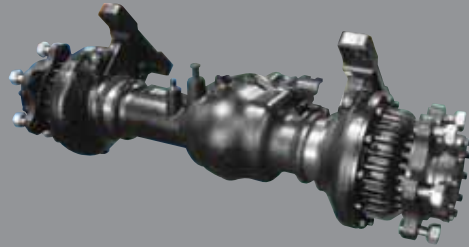

■ Some of the photos may include optional equipment.



Large Footboard & Hand Grip

Wide "open" step offers convenience and safety when entering and exiting truck.



Expansion Bellows

The expansion bellows absorbs vibration and reduces noise generated from the exhaust gas system and also extends the life cycle of exhaust gas system.



Electrically Monitored Air Filter

Air cleaner sensor alerts the operator of a restricted air filter and allows replacement before damage.



Heavy Duty Single Unit Frame

Heavy duty single unit type frame, designed on the basis of accurate structural analysis, guarantees durability and safety.



Bright, Protected Headlights

Bright, Protected head lights are positioned for exceptional visibility.

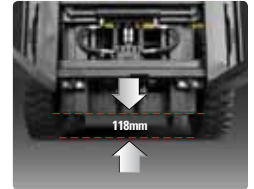

Ground Clearance

The engine and transmission are assembled horizontally and positioned high in the frame to protect major components during operation on rugged surface.

Designed for quick and easy service!

An ideal arrangement of component parts ensures easy access and convenience for maintenance.



Easy Change Air Cleaner

The air filter is readily accessible for cleaning or replacement. (6inch Cyclone Type)



Fast Service Access for Daily Fluids Check



Rotational Battery Installation



One Touch, No Tool Floor Plate



Removable Side Panels for Ease of Service



Improvement in Maintenance of Electric Parts

Various electric parts are centralized in dash board resulting in effortless troubleshooting.



Easy Maintenance Oil Check

The T/M oil level can be checked easily without any disassembly.



Brake Fluid Reservoir

Highly visible, easily accessible reservoir makes for quicker daily inspections.



An Accessible, Compact Fuse Box for Easy Inspection

Mast Specification

Mast Type	Overall Height Lowered (mm)	Maximum Fork Height (mm)	Tilt Angle (deg)	Free Lift (mm)				Load Capacity w/ o Integral Side Shift 500mm LC (kg)				Load Capacity w/ Integral Side Shift 500mm LC (kg)				Truck Weight Unload (kg)						
				With Backrest		With/ o Backrest		Single Tire		Double Tire		Single Tire		Double Tire		Single Tire	Double Tire					
				25L-7A/25G-7A/30L-7A/30G-7A	25L-7A/25G-7A	30L-7A/30G-7A	Fwd	Bwd	25L-7A/25G-7A/30L-7A/30G-7A	25L-7A/25G-7A/30L-7A/30G-7A	25L-7A/25G-7A/30L-7A/30G-7A	25L-7A/25G-7A/30L-7A/30G-7A	25L-7A/25G-7A/30L-7A/30G-7A	25L-7A/25G-7A/30L-7A/30G-7A	25L-7A/25G-7A/30L-7A/30G-7A	25L-7A/25G-7A/30L-7A/30G-7A	25L-7A/25G-7A/30L-7A/30G-7A	25L-7A/25G-7A/30L-7A/30G-7A				
2-Stage Limited Free Lift	V300	3000	2025	2040	6	10	155	155	155	155	2500	3000	2500	3000	2500	3000	2500	3000	3747	4247	3787	4284
	*V330	3300	2175	2190	6	10	155	155	155	155	2500	3000	2500	3000	2500	3000	2500	3000	3766	4268	3806	4304
	V350	3500	2275	2290	6	10	155	155	155	155	2500	3000	2500	3000	2500	3000	2500	3000	3783	4285	3823	4322
	V370	3700	2425	2440	6	10	155	155	155	155	2500	3000	2500	3000	2500	3000	2500	3000	3805	4308	3845	4345
	V400	4000	2575	2590	6	10	155	155	155	155	2450	3000	2500	3000	2475	2950	2500	2975	3835	4339	3875	4376
	V430	4300	2725	2740	6	6	155	155	155	155	2400	2925	2475	3000	2400	2875	2450	2925	3887	4392	3927	4428
2-Stage Full Free Lift	V450	4500	2875	2890	6	6	155	155	155	155	2350	2875	2425	2950	2350	2825	2400	2875	3909	4414	3949	4451
	V470	4700	2975	2990	6	6	155	155	155	155	2325	2825	2400	2925	2325	2750	2375	2825	3923	4430	3964	4466
	V500	5000	3125	3140	6	6	155	155	155	155	2275	2775	2350	2850	2275	2650	2300	2775	3945	4452	3986	4489
	VF290	2932	2025	2040	6	6	845	880	1377	1314	2500	3000	2500	3000	2500	3000	2500	3000	3792	4288	3833	4324
	VF320	3232	2175	2190	6	6	995	1010	1527	1464	2500	3000	2500	3000	2500	3000	2500	3000	3826	4323	3867	4359
	TF370/TS370	3700	1825	1840	6	6	645	660	1177	1114	2460	3000	2500	3000	2450	2900	2500	2950	3883	4397	3924	4433
3-Stage Full Free Lift	TF400/TS400	4000	1925	1940	6	6	745	760	1277	1214	2400	2925	2475	3000	2400	2850	2450	2900	3907	4422	3948	4458
	TF430/TS430	4300	2025	2040	6	6	845	880	1377	1314	2350	2850	2425	2925	2350	2775	2400	2825	3925	4444	3966	4480
	TF450/TS450	4500	2125	2140	6	6	945	960	1477	1414	2300	2800	2375	2875	2325	2725	2350	2775	3947	4469	3988	4505
	TF470/TS470	4700	2175	2190	6	6	995	1010	1527	1464	2250	2775	2350	2825	2275	2675	2300	2725	3960	4483	4001	4519
	TF500/TS500	5000	2275	2290	6	6	1095	1110	1627	1564	2200	2700	2275	2775	2200	2600	2275	2675	3983	4506	4024	4542
	TF550/TS550	5500	2475	2490	6	6	1295	1310	1827	1764	1700	2600	2200	2675	1700	2525	2200	2575	4022	4550	4063	4586
TF600/TS600	6000	2675	2690	6	6	1495	1510	2027	1964	1150	1600	2100	2575	1150	1750	2100	2475	4087	4620	4128	4656	
4-Stage Full Free Lift	QF610	6115	2177	2175	3	3	39.3	37.6	59.5	57.0	1600	1800	1850	2250	1530	1710	1750	2220	4297	4767	4337	4804
	QF660	6615	2377	2375	3	3	47.1	47.0	67.4	64.9	1500	1700	1750	2200	1430	1610	1650	2070	4356	4827	4396	4864
	QF700	7015	2477	2475	3	3	51.1	51.0	71.3	68.9	1400	1500	1700	2150	1330	1420	1600	2020	4387	4857	4427	4894
	QF745	7465	2627	2625	3	3	57.0	56.9	77.2	74.8	1100	1200	1600	2050	1040	1120	1510	1930	4433	4903	4473	4940
QF790	7915	2777	2775	3	3	62.9	62.8	83.1	80.7	700	750	1000	1100	650	680	920	990	4533	5004	4573	5041	

* TS-Mast : Wide Visible 3 Stage Full Free Lift Mast with 2 Free Lift Cylinders.

Load Capacity

25L-7A
25G-7A

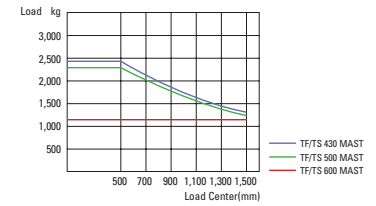
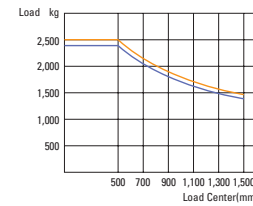

30L-7A
30G-7A

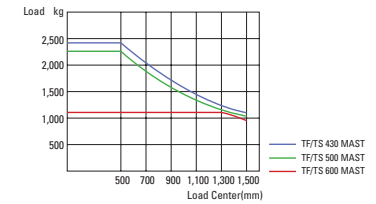
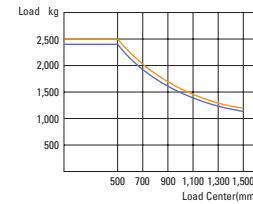

Optional Items

- CABIN & HEATER
- SIDE SHIFT
- INTEGRAL SIDE SHIFT
- FORK : 900mm, 1,000mm, 1,200mm, 1,350mm, 1,500mm, 1,650mm, 1,800mm
- OVER SHOE : 1,300mm, 1,500mm, 1,700mm, 1,800mm
- TILTING : 6/6', 3/3'
- TIRE : Cushion, No-marking, Double
- SEAT : Pocket, Arm Rest, Hip Rest
- LPG CLAMP : Swing Out, Swing Down
- M.C.V : 4-Spool
- ATTACH PIPING : 3 Spool-piping, 4 Spool-piping
- MASTER SWITCH
- BEACON LAMP
- HAZARD SWITCH
- WORK LAMP
- BRAKE PEDAL
- Hydraulic Booster (w/o Accumulator)
- SPEED CONTROL SENSOR